



# OPERATION AND MAINTENANCE MANUAL FOR RIKEN COMPACT INFRARED GAS MONITOR MODEL RI-557

## • Request for the Customers

- Read and understand this operating manual before using the detector.
- You must operate the detector in accordance with the operating manual.
- Regardless of warranty period, we shall not make any compensation for accidents and damage caused by using this product.  
The compensation shall be made only under the warranty policy of products or parts replacement.
- Because this is a safety unit, a regular maintenance for every six months and daily maintenance must be performed.
- If you find abnormalities in the detector, please notify them to our local representative immediately.

## **RIKEN KEIKI Co., Ltd.**

**2-7-6 Azusawa, Itabashi-ku, Tokyo, 174-8744, Japan**

Phone : +81-3-3966-1113

Fax : +81-3-3558-9110

E-mail : [intdept@rikenkeiki.co.jp](mailto:intdept@rikenkeiki.co.jp)

Web site : <http://www.rikenkeiki.co.jp/english/>

## [CAUTIONS ON OPERATION]

This is an infrared single gas monitor designed to measure one of the specified gas for carbon monoxide, carbon dioxide or methane in air.

The gas monitor is a safety instrument, not an analyzer nor measuring instrument to make quantitative and qualitative analysis or measurement.

Please understand following points and use this monitor correctly.

1. This gas monitor may respond to other gas and vapors than the target gas.

Be care to alarm action by interference.

It may fluctuate against the environmental(temperature, humidity, etc.) change around the monitor.

Perform zero adjustment with regular interval(approx once a month).

2. Avoid to use this monitor at the place where the temperature is drastically(approx 10 ~15°C) changed.

3. Alarm level shall be set within the performance of this monitor.

If set below our standard alarm level(20% of full scale), it may be caused to false alarm.

4. This is not a control equipment, but a safety instrument.

Use the alarm contact from this monitor only for an external alarm light or buzzer.

And the analog output signal shall be used only for an external indicator or recorder.

We do not assume indemnification for any accident or damage caused by other control purpose than the above.

5. Gas sampling from places where there are high humidity, dust or acid mist requires sample pre-conditioner.

Please consult our nearest agent or Riken Keiki for such applications.

6. For maintenance, replacement parts listed in this manual and adjustments are required.

We also recommend to perform regular maintenance including gas calibration in every 6 months as this is a safety instrument.

---

# CONTENTS

---

1. PRODUCT OUTLINE	
1-1 Preface .....	3
1-2 Application for use .....	3
1-3 Identification of each caution mark .....	3
2. IMPORTANT INSTRUCTION FOR THE SAFETY	
2-1 Danger items .....	4
2-2 Warning items .....	4
2-3 Caution items .....	5
3. PRODUCT FUNCTIONS	
3-1 Name of each part and functions .....	6
3-1-1 Configuration .....	6
3-1-2 Front panel .....	8
3-2 Block diagram .....	9
3-2-1 Electric diagram .....	9
3-2-2 Piping diagram .....	9
4. HOW TO USE	
4-1 Before operation .....	10
4-2 Installation place .....	10
4-3 Mounting the dust filter .....	12
4-4 Caution in the system engineering .....	12
4-5 Grounding .....	15
4-6 Caution in wiring .....	15
4-7 Applicable cable .....	16
4-7-1 Power cable .....	16
4-7-2 Output signal .....	16
4-7-3 Cable for alarm contact .....	16
4-7-4 Specifications of terminal plate .....	16
4-8 Arrangement of terminal plate .....	16
4-9 Caution in piping works .....	17
5. OPERATION METHOD	
5-1 Preparation to start-up .....	18
5-2 Basic performance flow .....	18
5-3 Start-up .....	19
5-3-1 Power ON .....	19
5-3-2 Adjusting the sample flow rate .....	20
5-4 Explanation of performance .....	20
5-4-1 Display action .....	20
5-4-2 External output action .....	22
5-5 Adjustments .....	23
5-5-1 Zero adjustment .....	23
5-5-2 Span adjustment .....	26
5-6 Alarm test (Confirming a transmission status) .....	29
5-7 How to finish operation .....	29

6. KIND OF ALARM AND ITS ACTION	
6-1 Kind of alarm .....	30
6-2 Alarm action .....	30
6-3 Gas alarm (The unit with alarm setting).....	31
6-3-1 Responding to gas alarm.....	31
6-3-2 Gas alarm possibility except the case of gas detection.....	31
7. MAINTENANCE CHECK	
7-1 Frequency of maintenance and check items .....	32
7-1-1 Daily check .....	32
7-1-2 Regular maintenance check .....	32
7-1-3 Maintenance contract for regular check .....	32
7-2 Replacing the parts .....	33
7-3 Treatment when stopping operation or move its installation place ...	34
7-3-1 Stopping the normal operation .....	34
7-3-2 Changing the installation place .....	34
7-4 Storage or treatment when not in use for a long period and treatment for re-use.....	34
7-5 Recommendable spare parts for regular maintenance .....	35
8. RESPONDING TO THE ABNORMAL CASE	
8-1 Trouble alarm .....	36
8-2 Responding to the trouble .....	36
8-3 Before it is thought to be trouble.....	36
8-4 Troubleshooting.....	37
9. DEFINITION OF TERMS.....	39
10. DETECTION PRINCIPLE .....	40
11. LIST OF PRODUCT SPECIFICATIONS	
11-1 Standard specifications .....	41
11-2 Product compositions .....	42
11-3 List of detection gas and range .....	42

# 1 . PRODUCT OUTLINE

## 1 — 1. Preface

First of all, we wish to express our heartfelt thanks for your purchase of our RI-557 Compact Infrared Gas Monitor.

This instruction manual is just a guide book to operate our gas monitor Model RI-557.

Your kind reading of this manual is requested not only for first user but for already experienced staff.

## 1 — 2. Application for use

The Riken Model RI-557 is a compact, single gas infrared monitor designed to measure one of the specified gas and range for 1) carbon monoxide, 2) carbon dioxide or 3) methane in air. The sample gas is drawn into this lightweight and rugged unit by an internal pump and is then analyzed through a Non-Dispersive Infrared Ray Absorption detector. A recorder output is standard to enable convenient and easy recording of your readings. Model RI-557 is powered on AC mains provide with LCD digital display to meet the extensive utility such as in automotive, environmental control, laboratories, university laboratory, research institutes and many others.

## 1 — 3. Identification of each caution mark



Indicates an imminently hazardous situation which, if not avoided, will result in death or serious injury or serious damage to the product.

This signal word is to be limited to the most extreme situation.

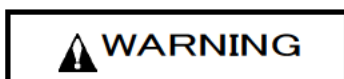

Indicates a potentially hazardous situation which, if not avoided, could result in death or serious injury on the human body or object.

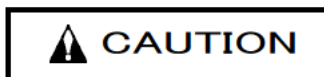

Indicates a potentially hazardous situation which, if not avoided, may result in minor or moderate injury or some damage on the human body or objects. It may also be used to alert against unsafe practices.



This means “ADVICE” at operation.

## 2 . IMPORTANT INSTRUCTION FOR THE SAFETY

### 2 – 1. Danger items



#### DANGER

- This monitor is not a explosion proof.  
Never detect the gas above their lower explosive limit.
- When intending to detect toxic gas such as carbon monoxide, etc., take enough consideration for both gas inlet and out / exhaust tubings not to give a danger to human body.

### 2 – 2. Warning items



#### WARNING

- Handling this monitor  
Perform the operation and maintenance of this monitor by enough knowledgeable and skilled person.
- Power source  
Before turning the power on, check that the specified voltage is within the supplied voltage. Then, turn the power on.
- Necessity of Grounding  
Do not cut the protective ground both inside and outside of instrument. Or, do not disconnect the connection of the ground terminals.
- Defect of Protective Function  
Before start operating, check if any defect is not found on the protective grounding. If there is any defect on the protective functions such as protective grounding or fuse, do not start the operation.
- Fuse  
To protect the instrument from fire, use the specifically rated fuse. When replacing the fuse, turn off the power inside of the panel, and the power source as well. Do not use fuse that is not specified, or do not make a short-circuit inside of the fuse holder.
- Operation in Gas  
Do not operate the instrument in a atmosphere of combustible gases, explosive gases or vapor. It is very dangerous to operate the instrument under such circumstances.
- External connections  
Confirm that the outer equipment is connected to this monitor correctly.
- Treatment at Gas Alarming  
It is very dangerous if the instrument detects the gas exceeded the alarm points. Take any treatment based on your judgment at that time.

## 2—3. Caution items



### CAUTION

- Do not use a walky-talky around the instrument.  
The indication might be affected by the electric wave generated by the walky-talky if it is used near the instrument. When the walky-talky is used, be away enough from the instrument not to affect.
- Take at least 5 seconds interval when re-turning the power on.  
Normal operation cannot be performed if the power is re-turned on within 5 seconds.
- Confirm the float of the flowmonitor is within two red bars.  
If the float is not within the red bars, the correct gas detection cannot be performed.  
Adjust the flow rate.
- Equip a dust filter to the instrument if it is used in a dusty place.
- Do not use this monitor to control other equipment by use of output from this monitor.  
This is not a control equipment.  
Do not connect outer equipment for control purpose.

## 3. PRODUCT FUNCTIONS

### 3-1. Name of each part and functions

#### 3-1-1. Configuration

【 Front 】

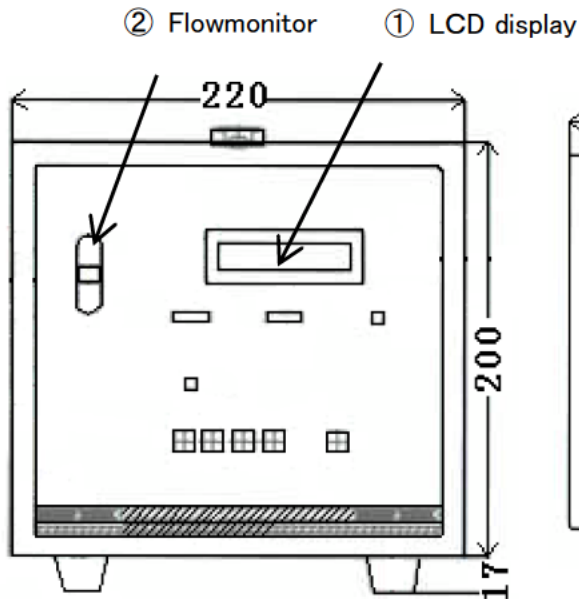

【 Side 】

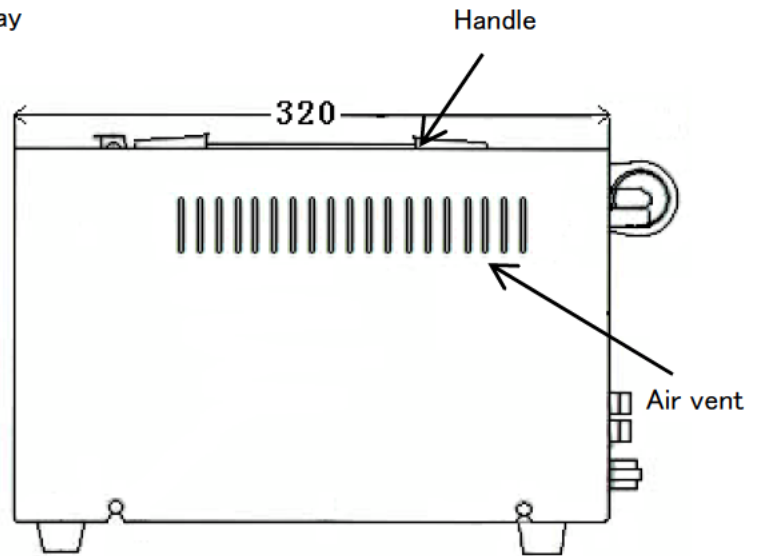

【 Back 】

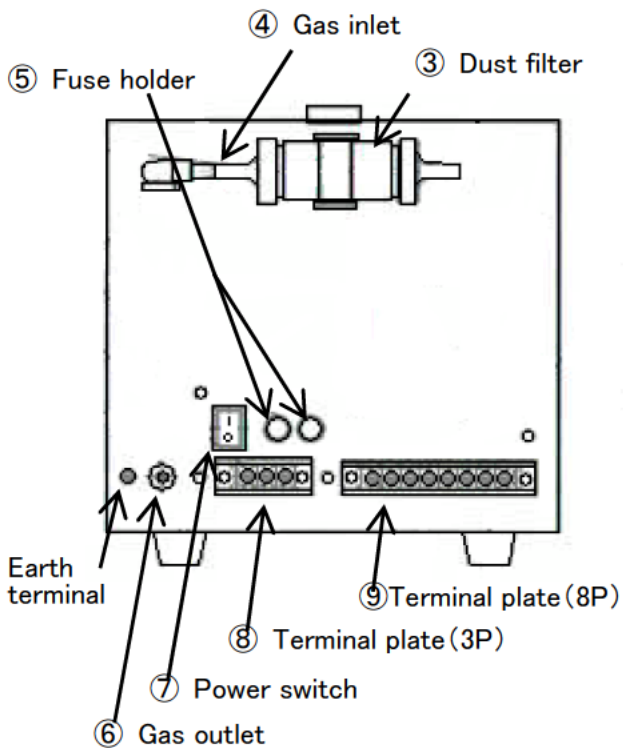

【 Top 】

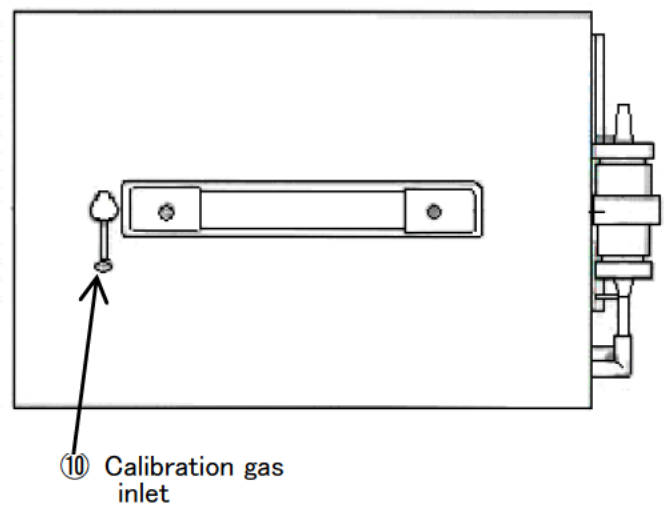



- ① LCD display : Displaying gas concentration and various messages.
- ② Flowmonitor : To confirm the suction flow.
- ③ Dust filter : To remove the dust containing in the sampled gas.
- ④ Gas inlet : Sampled gas inlet to this monitor.
- ⑤ Fuse holder : 2A fuses are mounted.
- ⑥ Gas outlet : Sampled gas outlet from this monitor.
- ⑦ Power switch : ON/OFF switch for power supply
- ⑧ Terminal plate (3P): Terminal strip for power source.
- ⑨ Terminal plate (8P): Terminal strip for outputs/relay contacts.
- ⑩ Calibration gas inlet: Inlet for canned calibration gas(zero/span adjustments).



**CAUTION**

•Put the cap onto calibration gas inlet in case you do not use calibration gas.

### 3-1-2. Front panel

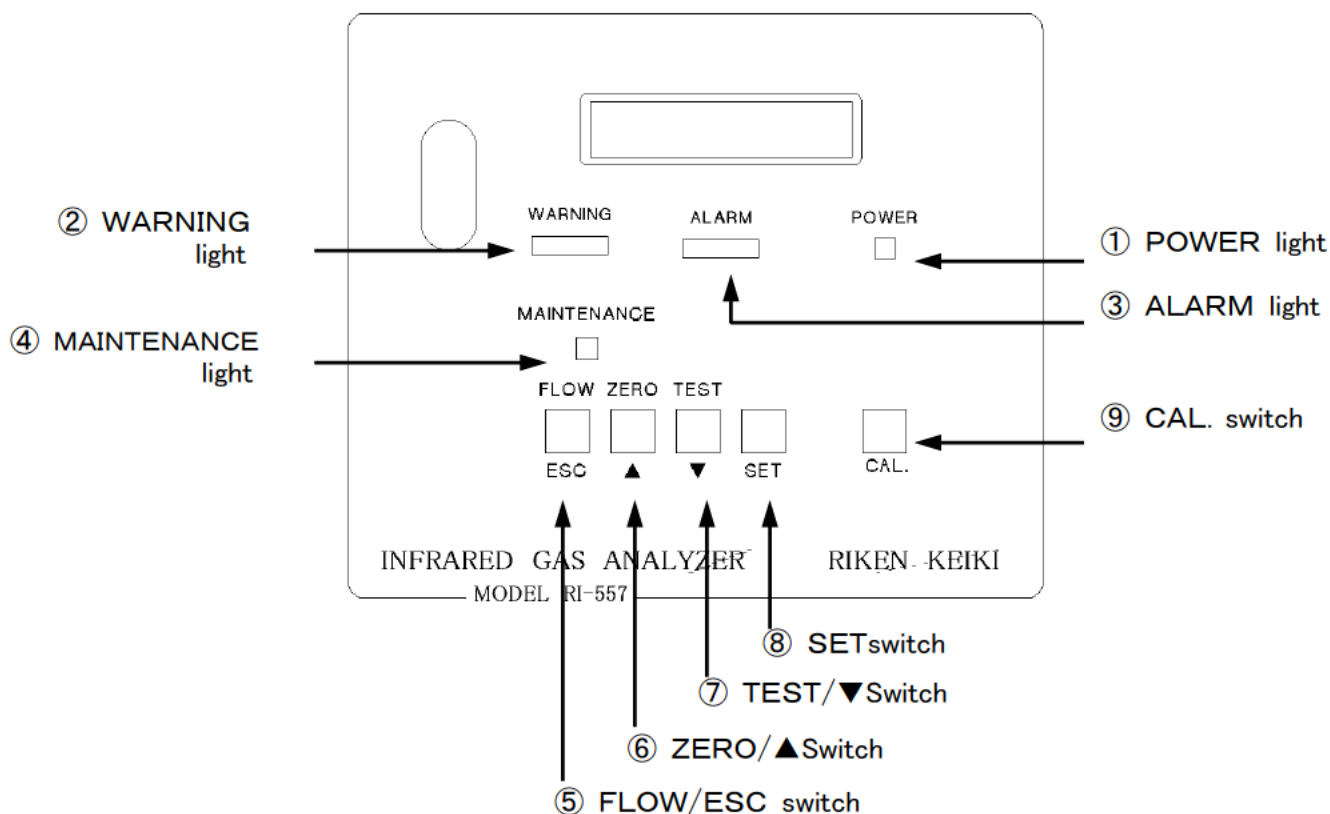

- |                     |  |
|---------------------|--|
| ① POWER light       | : Lighting in normal working and flashing in trouble condition.  |
| ② WARNING light     | : Flashing at the 1 <sup>st</sup> gas alarming (When alarm setting is on).                               |
| ③ ALARM light       | : Flashing at the 2 <sup>nd</sup> gas alarming (When alarm setting is on).                               |
| ④ MAINTENANCE light | : Flashing during zero and span adjustments.<br>Lighting during sampling pump is turned OFF.             |
| ⑤ FLOW/ESC switch   | : This is used to adjust the sample flow rate. It is also used to cancel the command in adjustment mode. |
| ⑥ ZERO/▲ switch     | : Uses for zero adjustment. This is also used to increase reading in adjustment mode.                    |
| ⑦ TEST/▼ switch     | : Uses to perform an alarm test. This is also used to decrease reading in adjustment mode.               |
| ⑧ SET switch        | : Uses to enter the content of various settings.   |
| ⑨ CAL. switch       | : Uses when performing span adjustment.  |

### 3-2. Block diagram

#### 3-2-1. Electric diagram

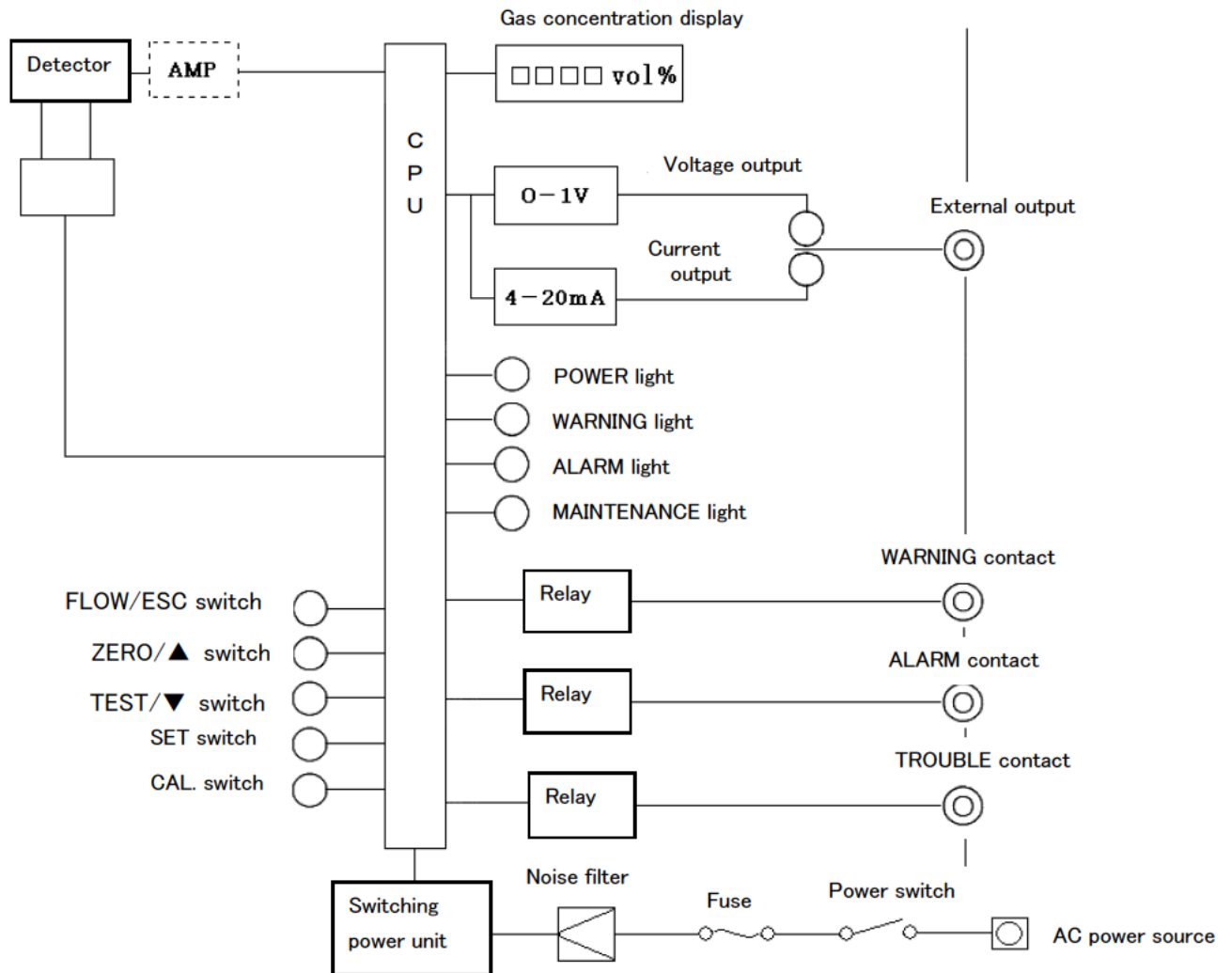

#### 3-2-2. Piping diagram

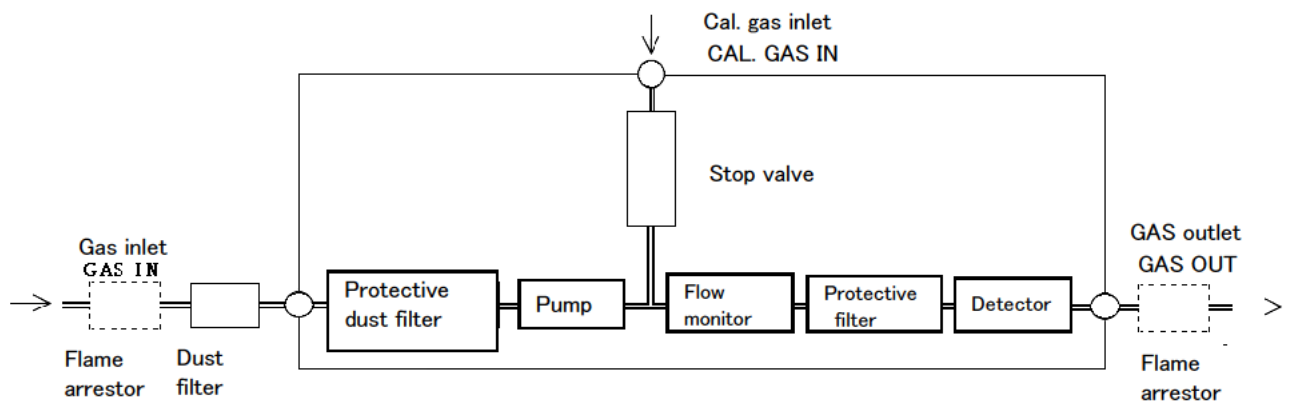

#### \* NOTE

- The flame arrester is a optional accessory.
- Contact our nearest agent or Riken Keiki for flame arrester.

## 4. HOW TO USE

### 4-1. Before operation

Be sure to keep caution items of use not only for first user but for already experienced staff. If not keep these caution items, the unit may be defective and correct gas detection may not be performed.

### 4-2. Installation place

It is easy to change the installation place since this is a transportable instrument. Select the installation place according to your application.



#### CAUTION

- Do not move this monitor during operation.  
Reading may be fluctuated by vibration.

Do not install this monitor in the following places



#### WARNING

Do not install at places where direct sun drought or where the temperature is drastically changed.

Keep away it at places where the temperature is drastically changed such as direct sun drought, around the ventilation blower outlet or direct wind blow.

It may not be followed to the drastically temperature change as the monitor inside is condensed. Also keep away from the place where the temperature is below 0°C or above 40°C.

Do not install it where rain or vapor splashes.

- Do not install it at the place where vapor, steam or water may be splashed.

Do not install it where vibration or shocks may take place.

The system consists of fine electronics parts.

Install them where to be stable not to crush or fall down.

Keep the system from the equipment which may generate the noise (Unit & cable).

Keep the system from the equipment which may give a high frequency in the surroundings and install it.

- Do not put the system jointly each.
- Do not wire the cable in parallel nor take access.

Do not install it where the target gas is deposited around.

Do not install at the place where the sample gas is deposited.  
Correct measurement will not be performed.

For instance, following consideration is required for CO<sub>2</sub> measurement. Since CO<sub>2</sub> gas contains approx 300~800ppm in atmosphere, zero adjustment shall be done by Nitrogen(N<sub>2</sub>) instead of atmospheric air. If zero adjustment is done by atmospheric air, detection error, especially for low measuring range, will be high.

Do not install it where it is attended with danger at maintenance work.

This detector requires regular maintenance.

Do not install the detector where it is attended with danger at maintenance work.

Do not install it where it will be danger for maintenance work.

- It is required to make regular maintenance. Do not install it where it will be danger for maintenance such as near the high electric power cable, et.

Do not install it where it is difficult to make maintenance.

Do not install the detector at places where;

- \* It is required to stop operation of the equipment where gas detector is installed at maintenance work.
- \* It cannot make maintenance without taking off a part of equipment.
- \* Casing cannot be removed by pipings, rack, etc.

Do not install it in an equipment that grounding construction is not enough.

Be sure to ground when install.

### 4—3. Mounting the dust filter

The performance of this unit will be interfered by dusts. Make sure to attach the dust filter to the detection gas inlet.

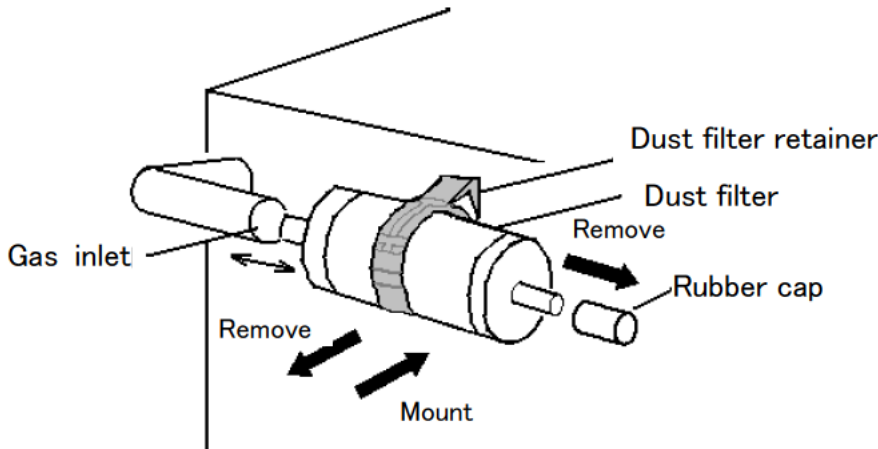

#### **⚠ WARNING**

- Be sure to mount the dust filter. If it is used without dust filter, water or dust will enter into the monitor and correct measurement cannot be performed. And it may be the cause of trouble.  
The dust filter is equipped to the monitor at the time of shipment.
- When replacing the filter, turn OFF the power to stop the pump suction before replacement.

### 4—4. Caution in the system engineering

#### **⚠ CAUTION**

- Unstable power and noise may cause error of performance and alarm.
- For the system to use this unit, it is required to make design based on this manual descriptions.

#### (1) Stable power used

While the system gets stable at power failure, the external output and alarm contact may be on and the care for it must be taken. In such case, use the standby battery or take an appropriate action in the receiver side.

Supply the following power to this unit .

Power voltage	Within 100VAC $\pm$ 10% or within 220VAC $\pm$ 10%
Power failure tolerance time	Approx 10msec. (For power failure above 10msec, it re-starts) To warrant the continuous operation, install the standby battery outside.
Others	Do not share a power source with the power involving high power load and high frequency noise. Use line filter and separate it from noise source according to the need.

(2) Designing to consider radiation

When install the closed self-standing control panel, mount the fans in the upper and lower part.

(3) Lightning measures

Lightning surge	There is the problem "Lightning". When make outdoor wiring of cable at factory or plants etc or when make a parallel wiring in the same duct with the cable in from outdoor even at the indoor wiring. If the lightning is a huge generation source, the cable is a reception antenna and there is the case that cable connecting instrument is broken. It is impossible to prevent the generation of lightning. If the cable should put in metal tube or laid in the underground, it is impossible to prevent the inductive lightning surge generating from the thunder.
Lightning measures	There is not the complete countermeasure for it but the following method can be considered. Make the suitable treatment accordingly. a)The transmission signal route is arranged for connection by the optical fiber cable etc. b)Countermeasure by the lightning arrester (Cable safety retainer). There is the way to install the lightning arrester just before the field apparatus and the central control station. The position of the lightning arrester installation is at each point of cable laid out from the outdoor to the indoor. The lightning arrester builds in the circuit to remove the surge voltage to be the source for the damage of field apparatus (Protection resistor, zero diode etc.) and is designed to protect the apparatus. But as the signal may be attenuated due to the lightning arrester, check the action and it is required to use.
Grounding	Surge noise shall be generated from the thunder lightning or except it. To protect detector from these cause, be sure to make grounding.

(4) Protection of alarm contact

- Alarm contacts shall be used only for external buzzer and alarm light, and do not use it for the controlling use (such as solenoid valve control etc).



**CAUTION**

- The each relay contact for WARNING, ALARM and TROUBLE is set at OFF(not functioning) as a standard version.
- Normally-closed contact (Break contact) at de-energized condition may change to open contact in a moment due to physical shock.
- Whenever alarm signals from gas detectors are used with normally-closed contact, please put delayed-circuit (for about one second) to receiver side of normally-closed contact to avoid such phenomenon.

When control the external load, the bad influence may be given to the system according to the load characteristics. In such case, the following countermeasure shall be taken to stabilize the action and protect the contents.

- Relayed by the low voltage relay and operate by connecting CR circuit (Spark Killer: SK) (Diode etc for DC) suited for relay coil directly to relay.

**\* NOTE**

- Add CR circuit to the load side of relay on the request.
- It may be better to add CR circuit to the contact side depending on the load.

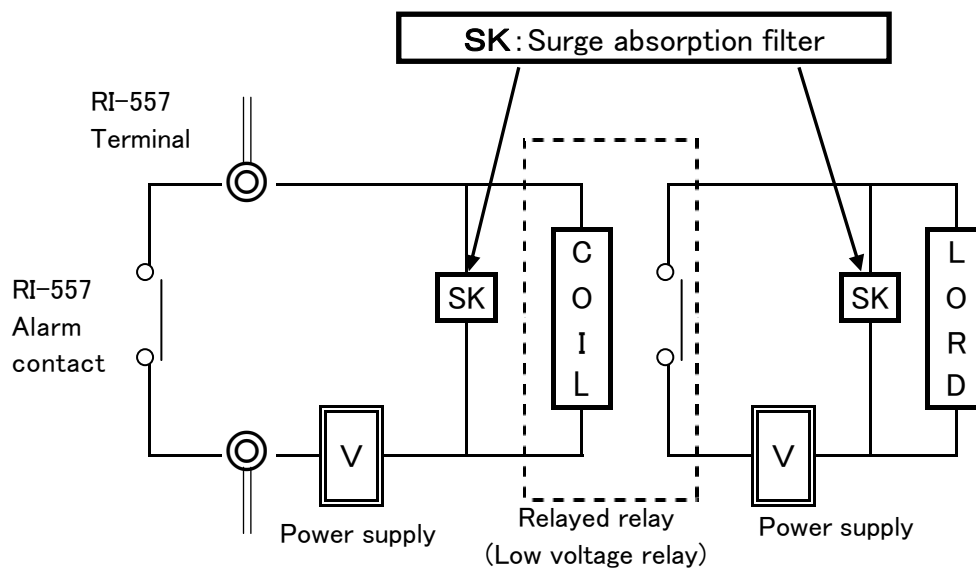

—How to think alarm contacts against inductive load—

The specification for alarm contact is described by the conditions of resistive load. When use the inductive load for alarm contacts, the very high reverse electromotive voltage may be generated and the following trouble tends to be produced.

- Contact part of relay is melted adhesively and the contacts can not work.
- High voltage is put inside of this monitor and then, electrical parts may be damaged.
- As it is big noise, the trouble action may be taken by the reckless drive of CPU.

**⚠ CAUTION**

- The inductive load shall not be connected in principle (Do not connect fluorescent lamp, motor, etc.).
- When use the inductive load, make the contact amplification outside. But as the outside relay coil belongs to the inductive load, use the relay driven by the low voltage (within AC100V) and it is protected by an appropriate surge killer.

\* As the inductive load, there are following samples.

- Revolving light
- External relay
- Buzzer
- Siren
- Fan
- Fluorescent lamp
- Motor etc.



## 4—5. Grounding

Be sure to make grounding before putting on the power.

### WARNING

Use the power cord(3P) or earth terminal at the rear side of this monitor when make grounding.

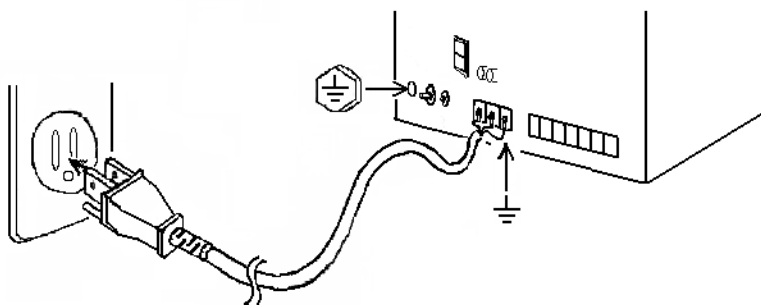

Be sure to make grounding for safety purpose and to keep stable operation of this monitor. Do not connect each wire with gas pipe. Make grounding corresponding to D-class grounding (Grounding resistance : below 100 Ω)

## 4—6. Caution in wiring

### CAUTION

•Do not lay down the power cable and signal cable together with motive cable.

## 4-7. Applicable cable

### 4-7-1. Power cable

Use the power cable supplied with the unit.

### 4-7-2. Output signal(4~20mA)

Use the CVVS shielded cable or equivalent.

### 4-7-3. Cable for alarm contact

Use the VCTF 0.75mm<sup>2</sup> cable or equivalent.

### 4-7-4. Specifications of terminal plate

#### 【Specifications of terminal plate】

- Rated voltage : 250VAC
- Rated current : 15A
- Port size : M4

【Suitable cable】 : MAX.1.25mm<sup>2</sup>

## 4-8. Arrangement of terminal plate

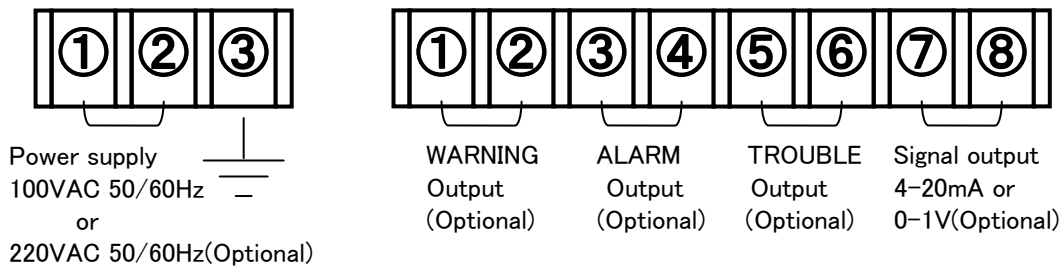

**DANGER**

•Set the terminal cover after wiring to avoid electrical shock.

## 4—9. Caution in piping works

### WARNING

- This unit is designed to sample the ambient gas in an atmospheric pressure. If the excessive pressure is added to gas inlet port and outlet port, it is dangerous that inner tubing will be disconnected and gas will be leaked. Use this unit not to adding excessive pressure.
- Connect the tube for exhaust gas to the gas outlet (GAS OUT) and exhaust the sampled gas to be the safety place.

#### (1) Piping to this gas monitor

Connection port for sample gas inlet provides a  $\phi 7$  hose nipple. Use the  $\phi 6$  (ID) hose. Connection port for sample gas outlet provides a  $\phi 6$  hose nipple. Use the  $\phi 5$  (ID) hose. The each length of hose for inlet and outlet shall be within 10m.

#### (2) Sample flow rate

The sample flow rate is approx 0.8~1.2L/min. in operating temperature range.

#### (3) Dust filter

Be sure to connect the dust filter supplied with accessories to the gas inlet port.

#### (4) Selection of piping material

- There are some high adsorptive gases in sample gas. Select the proper piping material by considering the kind of sample gas.
- Select the proper piping material by considering the co-existing gas and moisture.

### CAUTION

- Do not use this monitor in a high corrosive atmosphere.

## 5. OPERATION METHOD

### 5-1. Preparation to start-up

Before connecting the power cord, take care of the following. If not, there will be the danger of electric shock and the unit will be damaged.

- ① Make grounding
- ② Check that the wiring with the outer unit is made correctly.

#### DANGER

•Be sure to put the terminal cover after wiring to the terminal plate not to get an electric shock.

- ③ Check that the power voltage is within the rating.
- ④ During adjustment, there is the case to work alarm relay contact.  
Arrange not to affect the outside even if the contact work.
- ⑤ Check that the dust filter is connected correctly or not.
- ⑥ To prevent fire, check that the designated rated fuse is used.

### 5-2. Basic performance flow

Normally this is used in detection mode after making power on.

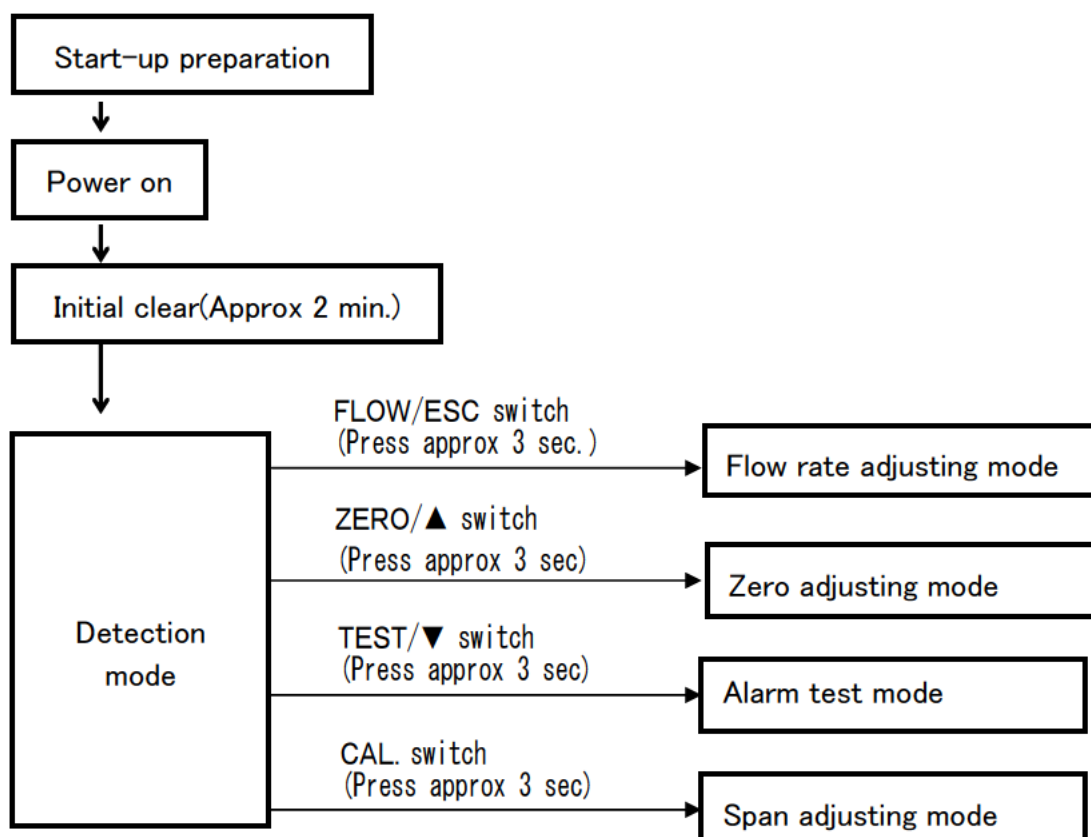

## 5-3. Start-up

### 5-3-1. Power ON

- ① Make sure to place the unit with properly before power on.
- ② Confirm location of the power switch.
- ③ The mark ( | ) means "ON" and ( O ) means "OFF".

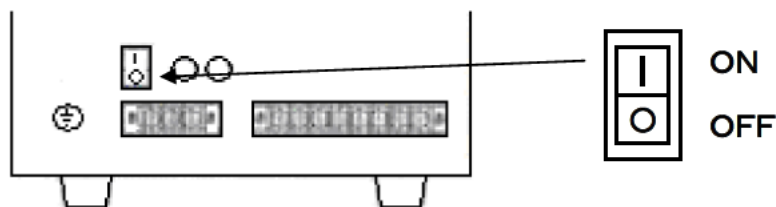

- ④ Push the power switch ( | ) "ON" to power on. Then, POWER light turns on and internal pump starts working.
- ⑤ During initial clear (2 minutes), the following actions are carried out.
  - System check
  - Operation for output : Approx. 2.5mA output
  - Operation for alarming.: Gas alarm(optional), trouble action(light, contact) shut-off
- ⑥ Check flow rate with flowmonitor. The small ball in the flowmonitor should be set between the RED lines.
- ⑦ It is not in the RED lines, adjust flow rate according to 【5-3-2 Adjusting the sample flow rate】

Flow chart of LCD display from Power ON to measurement.

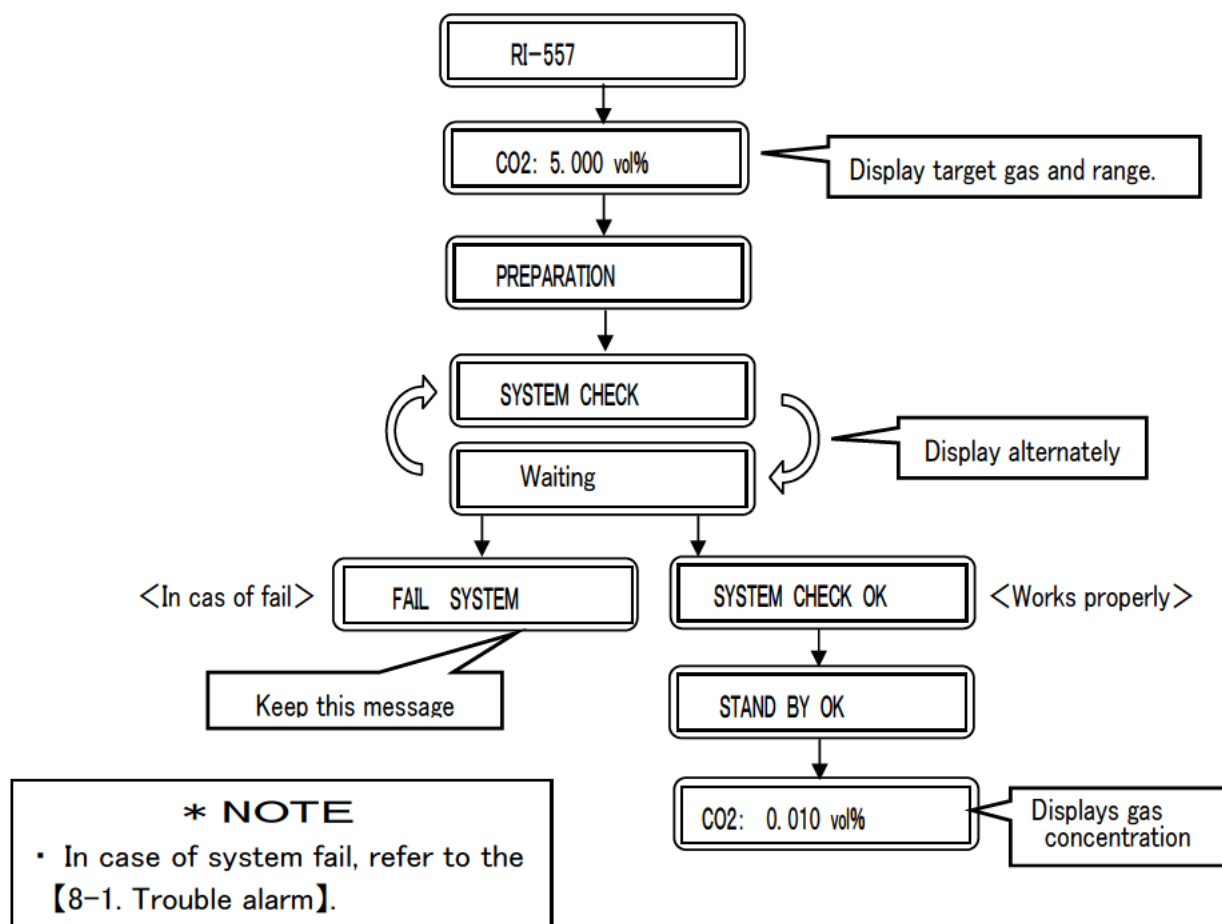

## 5 — 3 — 2. Adjusting the sample flow rate

Sample flow adjustment is set at flow rate adjustment mode.

- ① Press FLOW switch and hold 3 sec. during the unit is at initial clear or detection mode.

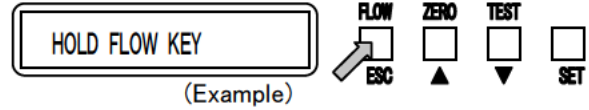

Then, you can enter flow adjusting mode. Press ESC switch and hold 3sec. again when you escape this mode without re-adjustment.

- ② During flow adjustment mode, “FLOW” is blinking on LCD. The ball should be set between RED lines of the flowmonitor. Adjust by pressing ▲/▼ keys.

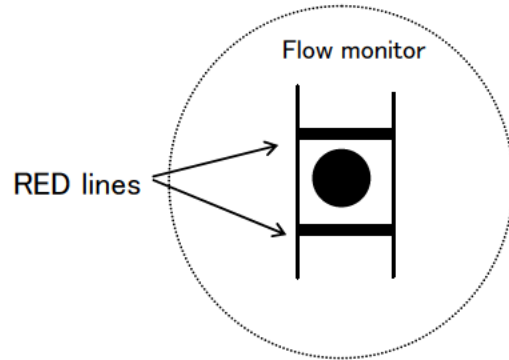
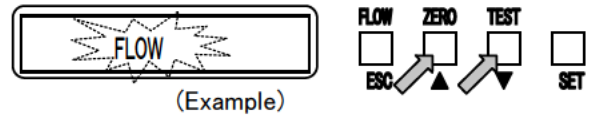

- ③ Press SET switch after adjustment. “FLOW” turns steady display and the units return to normal detection mode.

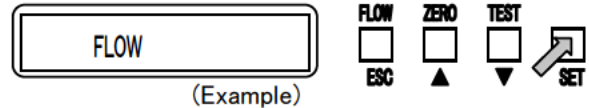

### \* NOTE

- Model RI-557 has automatic flow adjustment function. With internal flow sensor, it can check the low flow and then enhances suction ratio of internal pump. However, it alarms “FAIL FLOW” on LCD when it cannot get enough flow even after automatic flow adjustment.
- In this case, as the flow ratio was set maximum value by automatic flow adjustment, you cannot enter the Flow adjusting mode. Then, check the flow pass and filter if there are clogging and turn OFF the unit. You can enter the flow adjusting mode with the unit turn ON again. If you could not recover, contact our nearest agent or Riken Keiki.

## 5 — 4. Explanation of performance

### 5 — 4 — 1. Display action

This unit applies following two indicators.

- (1) LCD : Display gas concentration
- (2) LED light : POWER light ..... Indicates status of power supply and trouble condition  
 WARNING light ..... Lights on at 1<sup>st</sup> alarm  
 ALARM light ..... Lights on at 2<sup>nd</sup> alarm  
 Maintenance light ..... Lights on during maintenance mode

**\* NOTE**

•In order to explain the indication of LED lights, we use following notation and abbreviation. Working conditions of LCD and LED will be different from the status of the unit.

LED light notation

○:Light OFF ●:Lighting ◎:Blinking

LED light abbreviation

PW : POWER AL1: WARNING  
AL2 : ALARM MNT : MAINTENACE

•This unit has no zero suppression function.

Minus indication

When LCD display shows “-0.000vol%”, it means zero point is going down at minus.

● ○ ○ ○  
PW AL1 AL2 MNT

CO2: - 0.000 vol%

(Example)



**CAUTION**

•Zero adjustment is necessary to operate this unit properly when LCD display shows “-0.000vol%” according to **【5-5-1 Zero adjustment】**.

Full scale over

LCD display shows “OVER” in case the measuring gas concentration exceeds full scale range of this unit.

● ○ ○ ○  
PW AL1 AL2 MNT

CO2: OVER

(Example)

Alarm

When the unit detects the target gas which concentration is higher than WARNING or ALARM, these lights will be blinking.

● ◎ ◎ ○  
PW AL1 AL2 MNT

CO2: 3.500 vol%

(Example)

**\* NOTE**

•WARNING (1<sup>st</sup> alarm) and ALARM (2<sup>nd</sup> alarm) are optional functions.

Failure

LCD display shows following messages if some trouble would be happened.

<LCD display> ..... <Causes>

FAIL SYSTEM ..... System failure

FAIL SENSOR ..... Sensor failure

FAIL ZERO ..... Zero point failure

FAIL FLOW ..... Flow failure

◎ ○ ○ ○  
PW AL1 AL2 MNT

FAIL SENSOR

(Example)

**\* NOTE**

• Refer to **【8-1 Trouble alarm】** in case of trouble.

## 5-4-2. External output action

### 4-20mA version

(1) Signal transmission method : Electric current transmission (Max loop load 300 Ω)

(2) Signal level

- ① Detection mode : 4-22mA (Depends on gas concentration) ... (0-1V for 0-1V version)
- ② Initial clear : 2.5mA (Fixed) ... (0V for 0-1V version)
- ③ Zero/Span adjustment mode : 2.5mA (Fixed) ... (0V for 0-1V version)
- ④ Alarm test : 4-22mA (Depends on gas concentration) ... (0-1V for 0-1V version)
- ⑤ Failure alarm : 0.5mA (Fixed) ... (0V for 0-1V version)
- ⑥ Power OFF : 0mA ... (0V for 0-1V version)

Relations between gas concentration and signal output are shown below:

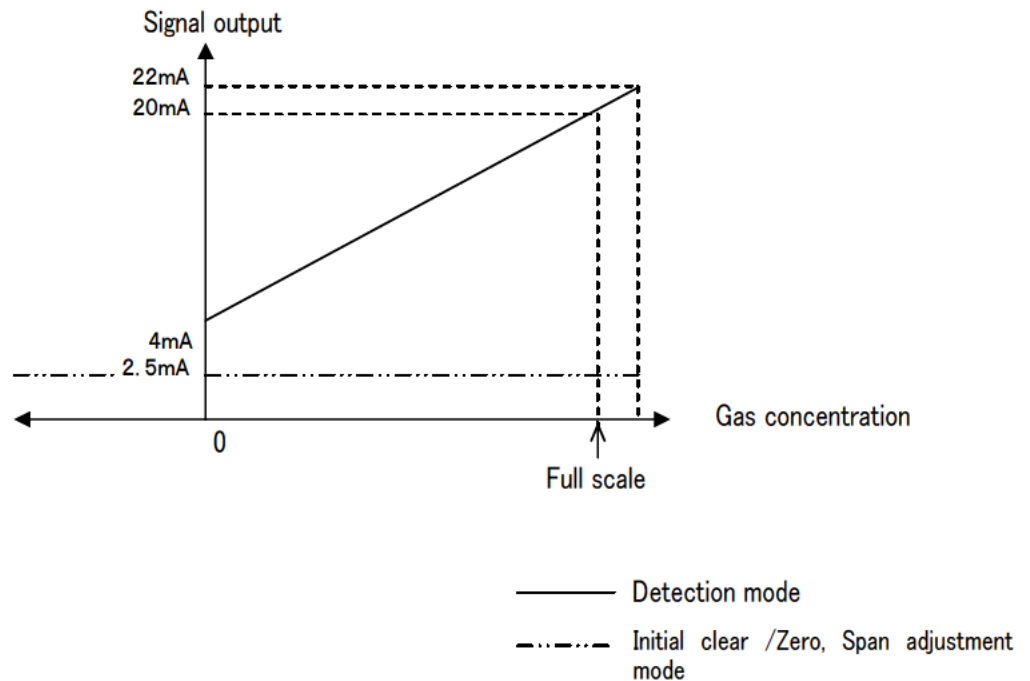

### CAUTION

- 4~20mA signal output has been adjusted before delivery. Do not attempt to adjust this output.
- Contact our authorized service agent if re-adjustment after installation is required.



## 5 — 5. Adjustments

### 5 — 5 — 1. Zero adjustment

Zero adjustment is done in zero adjustment mode.

Perform this adjustment regularly or at the time when zero point is moved.

#### CAUTION

- Zero point will not be stable just after power on (During warm-up operation). Do not adjust zero during warm-up operation, you cannot adjust it correctly. Zero adjustment shall be done after warm-up operation (More than one hour).
- When performing zero adjustment with zero gas, carry out it after reading gets stable.
- Zero adjustment shall be done in gas free places (fresh atmosphere)
- Normal adjustment cannot be performed if the detector is condensed.
- Use the designated calibration gas.
- Confirm the remainder when canned calibration gas is used (Use the canned gas containing above 0.1MPa)

- ① Press and hold ZERO switch for about 3 seconds to enter zero adjustment mode. (MAINTENANCE light blinks during zero adjustment mode. Press and hold ESC switch for about 3 seconds to return detection mode without zero adjustment).

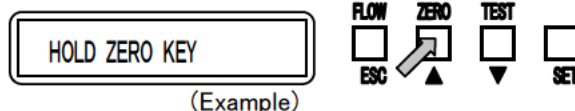

- ② Press SET switch when LCD shows **SET ZERO ?**. Then, you can enter zero adjustment mode.

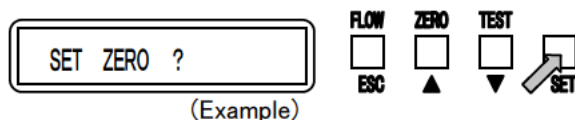

- ③ Select pump ON/OFF with ▲/▼ switch depending on the way of applying zero gas and then, press SET switch. (Check pump ON or OFF with flowmonitor).

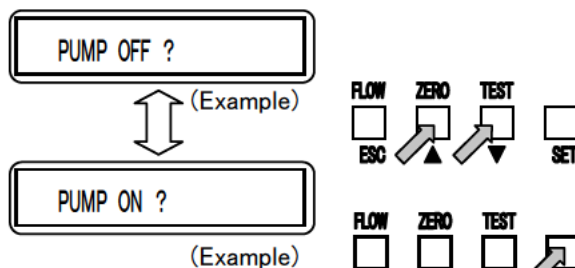

#### \* NOTE

When canned gas is used

→ PUMP OFF (MAINTENANCE light: Turns on)

When gas sampling bag is used

→ PUMP ON (MAINTENANCE light: Blinking)

- ④ LCD display shows current gas concentration with blinking. Apply zero gas and wait until the reading gets stable.

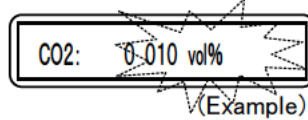

**\* NOTE**

**In case of using canned gas**

→ Apply zero gas as indicated the figure.

Then, supply the gas in 2~4 times every 2~3 seconds.

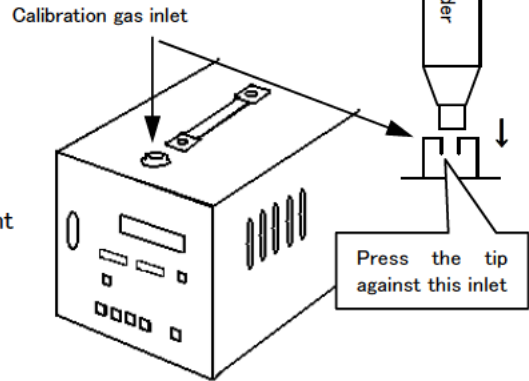

**Using gas sampling bag**

→ Supply zero gas from gas inlet located at the rear side of the unit as shown in right figure.

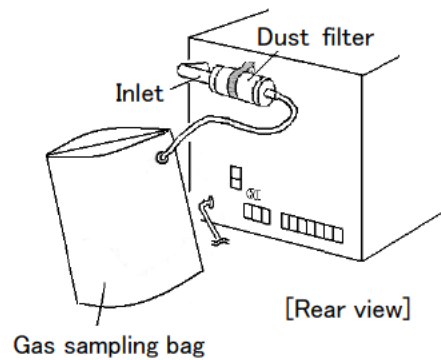

- ⑤ After zero is stable, press SET switch. Then, LCD display shows “ZERO SET OK” and the unit is back to normal detection mode.

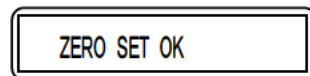

(Example)

Zero adjustment is succeeded.

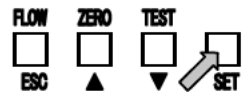

- ⑥ LCD display shows “PUMP ON ?” in case you set pump off before zero adjustment.

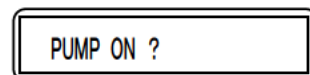

(Example)

Then press SET switch, and the pump works and it returns to detection mode.

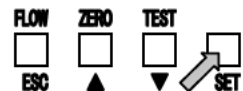

**\* NOTE**

When you use this unit first time or you have not used this unit for rather long term, zero point might be shifted. In such case, The unit automatically goes to fundamental adjustment mode from zero adjustment mode. See below instruction.

- Keep on applying zero gas and wait until the reading gets stable. After that, adjust the reading between 2950 mV and 3050 mV by pressing ▲ / ▼ switch. Wait for approx. 3 minutes until this adjusted value become stable.  
Press SET switch, and both zero adjustment and fundamental adjustment are completed. The unit is back to normal detector mode.

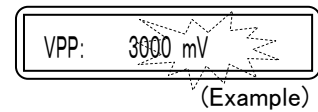
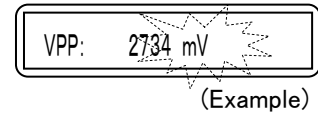

**Zero adjustment failure**

- ① If zero adjustment is failed, LCD display shows “*FAIL ZERO*”  
Then, back to normal measuring mode by pressing ESC switch or SET switch.

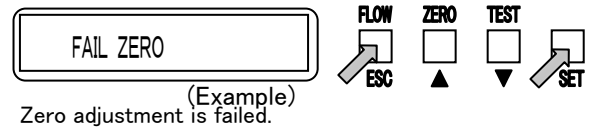

- ② LCD display shows “*PUMP ON ?*”  
in case you set pump off before zero adjustment. Then press SET switch, and the pump works and it returns to detection mode.

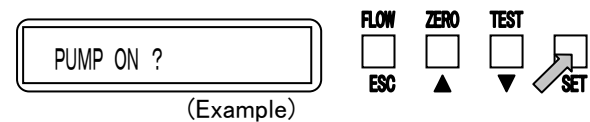

- ③ Check the unit and piping and try to attempt zero adjustment again. If it would not be adjusted zero, it may be caused by the sensor failure. Put off the power supply and contact our nearest agent.

## 5 — 5 — 2. Span adjustment

Span adjustment is done in span adjustment mode. Perform this adjustment periodically or if the sensitivity would be changed.

### CAUTION

- Span adjustment shall be done with calibration gas after the reading gets stable.
- Use the designated calibration gas for this adjustment.
- Confirm the remainder when canned calibration gas is used (Use the canned gas containing above 0.1MPa.)

- ① Press the CAL switch for about 3 seconds in detection mode to enter span adjustment mode (MAINTENANCE light blinks during span adjustment mode. Press ESC switch for about 3 seconds to return detection mode.)

HOLD CAL KEY  
(Example)



- ② Press SET switch.

SET SPAN ?  
(Example)

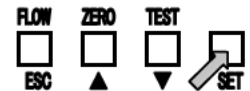

- ③ Select pump ON/OFF switch with ▲/▼ switch depending on the way of applying calibration gas and then, press SET switch. (Check the pump ON or OFF with flowmeter).

PUMP ON ?  
(Example)

↕

PUMP OFF ?  
(Example)

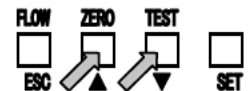

### \* NOTE

When canned gas is used

→ PUMP OFF (MAINTENANCE light : Turns on)

When gas sampling bag is used

→ PUMP ON (MAINTENANCE light : Blinking)

- ④ Current gas concentration is shown with blinking. Apply calibration gas.

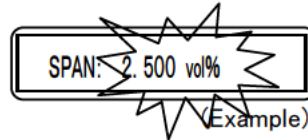

**\* NOTE**

**When canned gas is used**

→ Apply the gas from calibration gas inlet.  
Then, supply the gas in 2~4 times every 2~3 seconds as shown below graph.

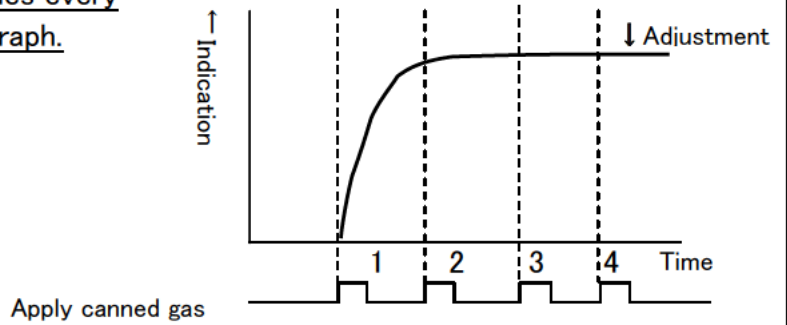

**When gas sampling bag is used**

→ Supply the gas from gas inlet located at the rear side of the unit.

See **【5-5-1. Zero adjustment】** for this inlet port.

- ⑤ The reading starts to increase. After reading gets stable, adjust it to the calibration gas concentration with ▲/▼ switch.

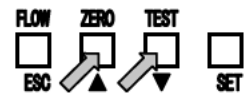
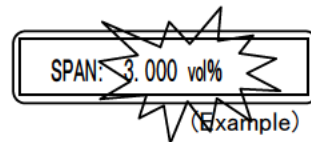

- ⑥ Press SET switch to save the adjusted value. When adjustment is performed correctly, the display shows "SPAN SET OK" and returns to detection mode.

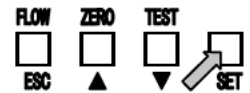
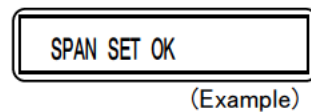

- ⑦ When adjustment is performed with pump off, the display shows "PUMP ON ?" after displaying "SPAN SET OK."

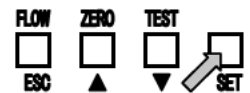
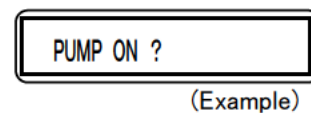

Then, press SET switch.

The pump works and the unit returns to detection mode.

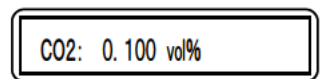
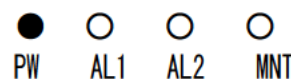

(Example)

**When SET switch is pressed in atmosphere without supplying the calibration gas.**

- ① If the SET switch is pressed in atmosphere without supplying the gas, span adjustment is not performed and it returns to detection mode.

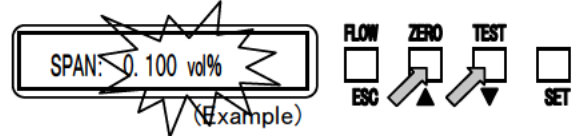
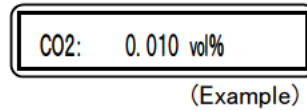
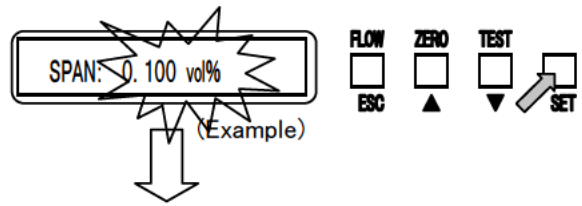

But, if you pressed SET switch by operating ▲/▼ switch, take care that the span adjustment will be done(When ▲/▼ switch is operated with gas concentration within 5% of full scale, the display shows “*FAIL SPAN.*”

**When span adjustment could not be performed.**

- ① If span adjustment could not be performed, the display shows “*FAIL SPAN.*”

Press SET or ESC switch to return detection mode.

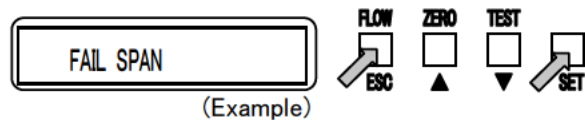

Span adjustment is failed.

- ② When adjustment was done at pump “OFF” condition, it displays

“*PUMP ON ?*” later. Pressing SET switch, pump works and it returns detection mode.

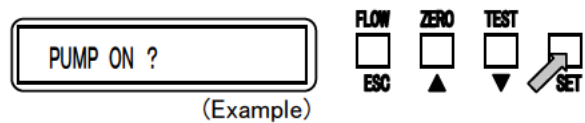

- ③ Check the unit and pipings and then, perform zero and span adjustments again.

Even so you could not perform span adjustment, gas sensor may be defective. Turn off the power and contact our nearest agent.

## 5 — 6. Alarm test (Confirming a transmission status)

This section is used to confirm the transmission status to the outer equipment by giving same gas concentration signal output. Alarm will be activated when test level exceeds preset alarm point if the unit provides an alarm function.



### WARNING

•When make alarm test (transmission test), announce it to respective department beforehand. Carry it out after making proper treatment (External signal output and alarm contact.)

- ① Press TEST switch for about 3 seconds to start alarm test mode.(MAINTNANCE light flashes during alarm test mode. If alarm test is not necessary, press ESC switch for about 3 sec, and it returns detection mode.

HOLD TEST KEY



### \* NOTE

Select the operation of the alarm contact setting during alarm test.  
 Select the NO-ACT or the ACT by ▲/▼ switch and SET switch.

NO-ACT : non work  
 ACT : work (TEST display is flashing.)

- ② Change the reading with ▲/▼ switch and confirm that the same gas concentration signal is output.

TEST: 0.000 vol%



TEST: 3.100 vol%

- ③ Press ESC switch for 3 sec to return detection mode.

CO2: 0.010 vol%

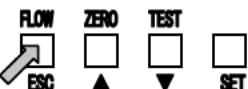

## 5 — 7. How to finish operation

- ① When finish this operation, check the external output and action of outer equipment to be connected with external alarm contact.
- ② Turn power switch of this unit to off position (O).
- ③ Stop the power supply to this unit.



### WARNING

•When finish this operation, do it after making proper treatment such as point skip with the upper system(Centralized system) etc.

•In case of detecting high concentration gas, high adsorptive gases or alcohol, turn off the power after sampling fresh air for about 5 minutes and making cleaning inside the unit.



## 6. KIND OF ALARM AND ITS ACTION

### 6-1. Kind of alarm

There are two kinds of gas alarm (optional) and trouble alarm.

#### (1) Gas alarm (WARNING, ALARM ...Optional)

When the detection gas reaches to preset alarm level or exceeds it, this starts to active.

#### \* NOTE

- We will set alarm action(WARNING, ALARM) on request.  
To prevent error of performance, it is required to set an alarm delay time separately.

#### (2) Trouble alarm (TROUBLE)

Trouble is detected in the detector and it gives an alarm as trouble alarm.

### 6-2. Alarm action

#### (1) Gas alarm (Optional)

When alarm function is provided, WARNING light(yellow) and /or ALARM light(red) turns on. The standard version is not set an alarm.

WARNING light and ALARM light are turned off in normal operation. When gas concentration exceeds preset alarm level, this light flashes and starts gas alarm action.

#### \* NOTE

- Alarm action is reset automatically when gas concentration decreases under preset alarm level.
- This unit has no audible alarm.

“Alarm pattern”

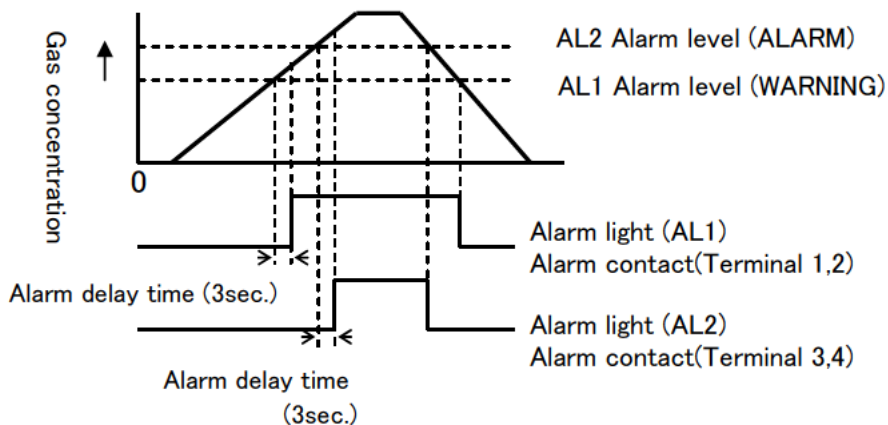



## (2) Trouble alarm

When the unit detects abnormality, POWER light (Green) flashes and relay contact for trouble alarm works.

### \* NOTE

- When the unit return to normal condition from trouble condition, it starts again from the action (initial clear) after power on, except the system trouble "FAIL SYSTEM.". See 【8-1 Trouble alarm】 for details.
- This unit has no audible alarm.

## 6 — 3. Gas alarm (The unit with alarm setting)

### 6 — 3 — 1. Responding to gas alarm

#### Reaction to leak gas

The counteraction at gas alarm shall follow to the client rule and immediate reaction shall be required.

Generally, the following action is taken.

#### ① Confirmation of indication value.

### \* NOTE

- Instantaneous gas leak may get lower at confirmation time.
- Except gas alarm, it gets alarm condition temporarily by noise or any other accidental conditions.

② Based on gas alarm control concentration, it keeps the safety by keeping away people from the monitoring area.

③ When gas concentration display is continued, close the gas valve and confirm that gas concentration gets lower enough.

④ Suppose that the leak gas is to remain and provide yourself with protection attire and tool away from danger, go to the leak site and check the gas residual condition by portable gas detector.

⑤ After checking that there is no danger, the treatment for gas leak shall be taken.

### 6 — 3 — 2. Gas alarm possibility except the case of gas detection

#### It may respond to interference gas

For interference gases, contact the nearest agent or Riken Keiki.

#### It may be caused by drifting due to the change of long time elapsed sensor

Check the reading by daily check and make calibration (zero and span) whenever necessary.

#### It may be caused by the noise generated from spherical machine

- Revision of installation location, wirings and the addition etc. of noise measure parts shall be required.
- It may receive a temporarily noise such as by thunder lightning etc.  
The measure for surge according to the condition can be taken.

## 7. MAINTENANCE CHECK

This is an important for security and safety. To maintain the security and enhance the reliability of safety, the regular maintenance check for it shall be absolutely necessary.

### 7-1. Frequency of maintenance and check items.

#### 7-1-1. Daily check

This is the check items carried out by customer.

① Check of flowmonitor

Check that the ball in flowmonitor of this unit is within two red lines. If not, adjust flow rate(See 【5-3-2 Adjusting the sample flow rate】).

② Check of PW/TR light

Check that the power light is at on condition. If it is flashing, check the contents of trouble.

③ Check of LCD reading

Check that LCD reading is zero (0) in fresh atmosphere or when zero gas is supplied. If it is not "0", make zero adjustment. (See 【5-5-1 Zero adjustment】)

④ Check and replacement of dust filter

Check the dirt of dust filter by eyes. If it is not within two red lines, adjust it according to 【5-3-2 Adjusting the sample flow rate】.

Even though it cannot move up, the filth of dust filter can be considered. Replace it with new one or check the flow path (clog, bend or crack of tubing).

#### 7-1-2. Regular maintenance check

The following items shall be checked at regular maintenance.

① Daily check

② Cleaning of this unit

③ Zero and span adjustments

④ Function check

⑤ Parts replacement (Refer to 【7-5 Recommendable spare parts for regular maintenance】)

#### 7-1-3. Maintenance contract for regular check

- To maintain the safety operation of the unit, it is recommended to keep the maintenance contract with service agent for regular maintenance, adjustment and overhaul etc including the gas sensitivity adjustment.
- For the detail of maintenance contract, contact our nearest service agent or Riken Keiki.

## 7 — 2. Replacing the parts



### CAUTION

- Contact our nearest agent for replacement of sensor and other parts.

#### Replacing the dust filter

If you could not bring the ball in flowmonitor within red lines even though you would try it, the filth of dust filter can be considered.

Replace it with new one.

- ① Turn power switch to “O” position (OFF).
- ② Remove the pawl in the center of retainer which is connected between the unit and dust filter.
- ③ Remove rubber connection for gas inlet side (you can detach dust filter)
- ④ Replace the dust filter with new one (Take care for mounting direction)

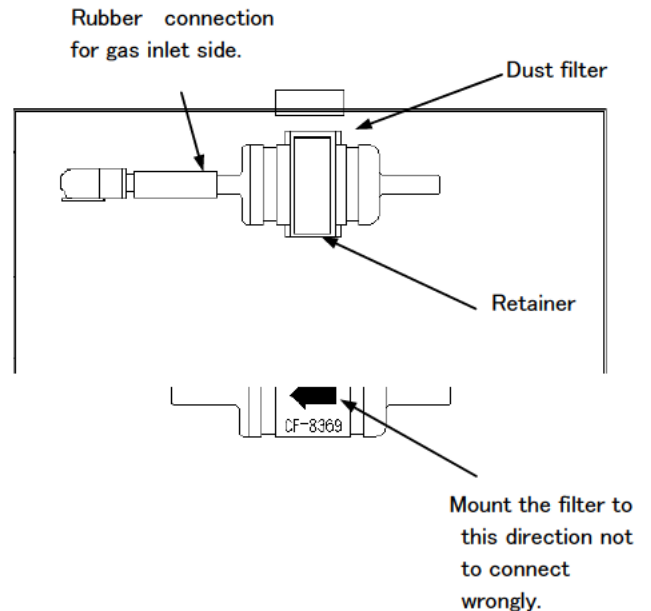

#### Replacing the fuse

If the display shows nothing when power is supplied, the fuse may be broken. Replace it with new one.

- ① Turn power switch to “O”(OFF) position and pull out the power cord from receptacle.
- ② Take off the fuse holder located at the rear of the unit with flat-blade screwdriver.
- ③ Replace the fuse (2A) with new one.
- ④ Mount the fuse holder as before.

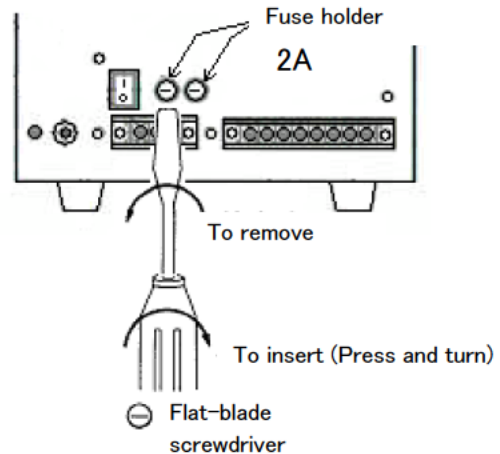

### DANGER

- Be sure to use the designated fuse.
- There is the fear of fire and it is very danger if undesignated fuse is used or the fuse is short-circuited.
- If the fuse would be broken again after replacement of fuse, contact our nearest agent or Riken Keiki.

### 7 — 3. Treatment when stopping operation or move its installation place

#### 7 — 3 — 1. Stopping the normal operation

See 【5-7 How to finish operation】

#### 7 — 3 — 2. Changing the installation place

When changing the installation place, refer to 【4-2 Installation place】 in advance.

Also refer to 【4-6 Caution in wiring】 and 【4-9 Caution in piping works】.



#### CAUTION

- Do not move the unit while in operation.  
Reading will be changed due to the vibration.
- Be sure to perform gas calibration when changing the installation place.
- Ask to our nearest agent for re-adjustments including gas calibration.

### 7 — 4. Storage or treatment when not in use for a long period and treatment for re-use.

This model must be stored under the following environmental conditions.

- In a dark place under the normal temperature and humidity away from direct sunlight.
- In a place where gases, solvents or vapors are not present.



#### CAUTION

- Be sure to perform zero and span adjustments when the unit is used again.
- The re-adjustment and parts replacement shall be contacted to our nearest agent.
- When installation place is moved from cold place to warm place, the inside of the unit will be condensed. Operation under such condition causes malfunction or trouble.  
In such case, leave the unit for a while, and then use it after inside temperature of the unit is equilibrated with ambient temperature.

## 7 — 5. Recommendable spare parts for regular maintenance

No.	Description	Check interval	Replacement interval	Q'ty/unit
1	Pump (Excluding diaphragm)	6 months	1~3 years	1 pce
2	Pump diaphragm	6 months	1~2 years	1 pce
3	Pump holder	1 year	3~6 years	1 pce
4	Detector (Sensor ass'y)	6 months	2~3 years	1 pce
5	Internal tubing	6 months	1~3 years	1 set
6	Switching regulator	---	4~6 years	1 pce
7	Printed circuit board(MAIN PCB)	---	6~7 years	1 set
8	LCD	1 year	7~8 years	1 pce
9	Fuse (2A)	---	8 years	2 pcs.
10	Flowmonitor ass'y	1 year	7~8 years	1 pce
11	O-ring for flowmeter	1 year	3~6 years	1 pce
12	External dust filter	6 months	0.5~1 years	1 pce
13	Protective dust filter	6 months	2~3 years	1 pce
14	Protective filter	6 months	2~3 years	1 pce
15	Stop valve	6 months	2~3 years	1 pce

### \* NOTE

- The replacement interval will change depending on operating condition and it does not mean the guarantee period.
- Replacement of printed circuit board is required due to the deterioration of capacitor.
- For printed circuit board, use pre-adjusted one.

## 8. RESPONDING TO THE ABNORMAL CASE

### 8 — 1. Trouble alarm

Flashing of PW/TR light

- When PW/TR light is flashing, it is the condition that the following trouble may be caused.  
Research its cause and contact our nearest agent.
- In case of trouble alarm, trouble alarm contact activates and 0.5mA(fix) signal is output.

Displays	Contents/ Probable causes	Recommended action
FAIL SYSTEM	Some abnormal condition would be happened.	Put on the power again. If it can not be recovered, even though you would repeat power ON and OFF.
FAIL SENSOR	Connection failure of the sensor connector or sensor part would be defective	Contact our nearest agent.
FAIL ZERO	A particle of dirt is accumulated inside of sensor.	Perform zero adjustment. If it can not be recovered, contact our nearest agent.
	Ambient temperature changes suddenly	If there is the direct rays of sun or high temperature generating device around the unit, zero point will fluctuate and an alarm may be actuated. Put a shield or protect the unit from sudden temperature change.
FAIL FLOW	Pump trouble or gas flow line is clogged	Check the clog of filter and gas flow line and cope with a problem. If it can not be recovered, contact our nearest agent.

### 8 — 2. Responding to the trouble

When any trouble was found on this unit, contact our nearest agent or Riken Keiki.  
If trouble should take place, we try best to search its cause and prevent its cause.

### 8 — 3. Before it is thought to be trouble

It may be originated from disconnection and short circuit between units.

- Check the wirings and periphery of related equipment to be connected with this unit.

There is the case that operation of the unit is not correct including piping work and installation work etc.

- Read operation manual and re-check operation procedure. Contact our nearest agent if there is still unclear point.
- This will be treated by the re-check of stand-by battery, electrical line filter, insulation transformer etc or those addition.

## 8 — 4. Troubleshooting

### (1) POWER light does not turn ON

- Is power switch at ON position ?  
→ Put power switch to ( | ) (ON) position.
- Is supply voltage correct ?  
→ Check the supply voltage and supply the rated voltage.
- Is power cable connected properly ?  
→ Connect power cable certainly.
- Is fuse disconnected ?  
→ Search the cause of disconnection and replace it by referring **【7-2 Replacing the parts】** after making countermeasures.

**\* NOTE**

Rating of the fuse for this unit is 2A.

### (2) POWER light is flashing

- See **【8-1 Trouble alarm】**.

### (3) The reading increases indefinitely

- Is the temperature around the unit changed suddenly or not ?  
→ The reading may be increased due to the direct rays of sun or sudden temperature change gas. Make a countermeasure not to change the temperature suddenly around this unit.
- Is temperature and humidity in sampling gas changed suddenly or not ?  
→ The reading may be increased due to the sudden temperature and humidity change in sampled gas. Make proper pre-treatment to be a constant conditions for the sampled gas.
- Is sample gas pressure changed or not ?  
→ The unit is affected by pressure. Make proper pre-treatment to be a constant pressure for the sampled gas.
- Is the unit affected by outside noise or not ?  
→ Reduce the outside noise by referring **【4-4 Caution in the system engineering】**.

### (4) Reading is over range

- Is inside detector dirty or not ?  
→ Check whether the filter is dirty by water, dust etc or not.  
In case of IR detector, the reading is affected if the cell in detector gets wet or dirty by water etc. In such case ask our nearest agent for repair.
- Is the unit affected by outside noise or not ?  
→ Reduce the outside noise by referring **【4-4 Caution in system engineering】**.

- (5) The unit has a indefinite action
- Is there outside noise or not ?
    - Turn off the power and turn on the power again for re-start of operation.  
When such takes place oftentimes, reduce the outside noise by referring 【4-4 Caution in system engineering】.
- (6) Zero adjustment is not possible
- Is it just after power on ?
    - Adjust zero after making warm up for more than 1 hour.
  - Is gas concentration for adjustment correct ?
    - Use the fresh air or nitrogen gas without containing target gas and interference gas.
  - Is inside unit condensed or not ?
    - Correct adjustment cannot be performed if piping and inside the unit are condensed. Do not install the unit where sudden temperature and humidity change takes place.
- (7) Span adjustment is not possible
- Is gas concentration for adjustment correct ?
    - Use the appropriate gas concentration for adjustment. If you could not adjust even though you used appropriate gas concentration, sensitivity may be dropped. Contact our nearest agent.
- (8) Slow response
- Is the dust filter clogged or not ?
    - Replace the dust filter.
  - Is the pipe at gas inlet side or gas outlet side broken or clogged ?
    - Take appropriate measure for wrong point.
  - Is sample flow rate correct ?
    - Adjust sample flow rate.
- (9) Fuse disconnection
- The trouble of this unit or trouble of external power source can be considered.
    - Search this cause and after taking its measures, replace the fuse with the designated one.

**\* NOTE**

- The fuse rating for this unit is 2A (Normal fusing).



## 9. DEFINITION OF TERMS

### Flowmonitor

This is a monitor to confirm the sampled gas flow.

### Output signal

Signals in general being output from this unit.

- Gas concentration signal : Electric current 4~20mA (or 0~1V as optional)
- Status signal : Electric current 4~20mA (or 0~1V as optional)
- Alarm contact : Relay contacts for WARNING, ALARM and TROUBLE.

### Dust filter

The goods to remove dust which gives bad influence to the functions by placing it in front of the unit.

### Full scale

The maximum value for detection range.

### Adjustment

To adjust instrument reading to the standard gas concentration using calibration gas, etc.

### Initial clear

The reading will be unstable for a few minutes after power on.

This means the initial action to prevent a fault alarm during this period.

During this period, a false signal (2.5mA for 4~20mA output or 0V for 0~1V output) is output and alarm contact shall be cut off.

### Zero suppression

This is a function to blur the environment change or the influence by interference gas.

## 10. DETECTION PRINCIPLE

Model RI-557 applies Non-Dispersive Infrared Ray Absorption(NDIR) technique to detect target gas.

The infrared beam emitted from the light source passes through the gas cell and reaches to IR sensor. The target gas enters into gas cell from gas inlet.

When target gas is entered into gas cell, the amount of infrared ray to be received by IR sensor decreases since the infrared ray emitted from IR source is absorbed by the target gas. This decreased amount is detected by IR sensor and output as gas concentration. There is a optical band pass filter in front of IR sensor which can pass the absorption wave of target gas. Then, there is no sensitivity for the gas which has the different absorption wave from the target gas. Furthermore, there is no sensitivity against N<sub>2</sub> and H<sub>2</sub> etc. which cannot absorb infrared ray.

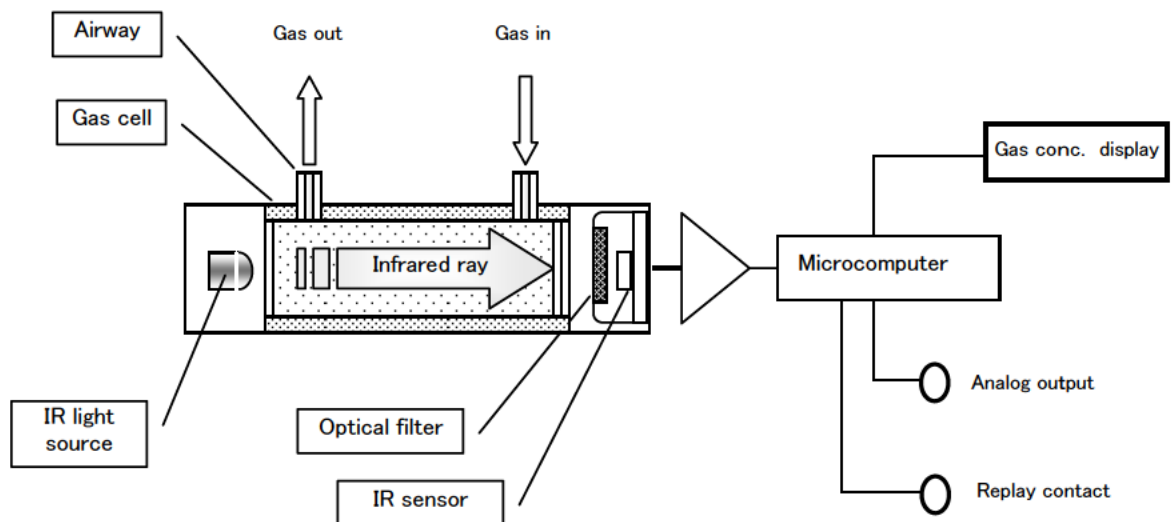

**Structure**  
(IR Detector)

# 11. LIST OF PRODUCT SPECIFICATIONS

## 11 — 1. Standard specifications

Model	: RI-557
Detection principle	: Non-Dispersive Infrared Ray Absorption (NDIR) method
Target gas	: Refer to the list of detection gas and range
Detection range	: Refer to the list of detection gas and range
Repeatability	: Within 2% of full scale (at constant conditions)
Linearity	: Within 3% of full scale (at constant conditions)
Response time	: Within 30 sec to get 90% of final reading (from the sample gas inlet of the unit).
Detection method	: Automatic sample drawing by internal pump. Sample flow rate : 0.8~1.2L/min Sample tubing connection : Sample side $\phi$ 6 ID tubing (Gas inlet $\phi$ 7) Exhaust side $\phi$ 5 ID tubing (Gas outlet $\phi$ 6)
Gas alarm (Optional)	: 2 levels (WARNING/ALARM), adjustable between 20% of full scale and full scale, non-latching. Relay contact : Dry contact, normally-open or normally-close contact for each step, rated 0.4A at 125VAC/2A at 30VDC(Resistive load).
Display functions	: Gas concentration .....16 digit LCD Status indication ..... 16 digit LCD and LED lights ① POWER (Green) : Normal...ON, Trouble...Flashing ② WARNING(Yellow) : Normal...OFF, Warning...Flashing ③ ALARM (Red) : Normal...OFF, Alarming...Flashing ④ MAINTENANCE (Green) : Zero adjusting ...Flashing Span adjusting...Flashing Pump OFF ... Lights ON (During zero/span adjustments)
Self-diagnostic function	: System failure, sensor connection failure, zero point failure.
Trouble alarm	: Flashing of POWER light, display of trouble contents. Relay contact : Not provided or Provided(Optional), dry contact, normally-open or normally-close(Optional) Rated 0.4A at 125VAC/2A at 30VDC(Resistive load)
Analog output	: 4~20mA(non-isolated, max signal load 300 $\Omega$ ) or 0~1V(non-isolated).
Warm-up time	: Approx 60 min after power on (Available to detect the gas 2 minutes later after power on)
Power requirement	: 100VAC $\pm$ 10%, 50/60Hz, Max 25VA or 220V $\pm$ 10%, 50/60Hz, Max35VA.
Operating temp & humidity	: 0~40°C, below 90%RH (Non-condensing)
Dimensions	: Approx 220(W) x 200(H) x 320(D) mm (Excluding projection)
Weight	: Approx 5.7kg.

## 11 — 2. Product compositions

### Standard compositions

- The main unit(RI-557) ..... 1 unit
- Standard accessories
  - Power cable ..... 1 pce
  - Operating instruction manual ..... 1 vol.
  - Inspection certificate ..... 1 sheet
  - Rubber tubing (1m) ..... 1 pce
- Optional accessories
  - Dust filter
  - Fuse (2A)
  - Gas sampling bag
  - Protective dust filter (for the inside of the unit)
  - Protective filter (for the inside of the unit)
  - Flame arrestor

## 11 — 3. List of detection gas and range

Detection range (vol%)	0~2	0~5	0~10	0~20	0~50	0~100
High range (vol%)	0.5~2	1~5	2~10	5~20	10~50	20~100
Resolution (vol%)	0.01	0.025	0.05	0.1	0.25	0.5
Low range (vol%)	0~0.5	0~1	0~2	0~5	0~10	0~20
Resolution (vol%)	0.005	0.01	0.02	0.05	0.1	0.2
Carbon monoxide (CO)	—	○	○	—	—	—
Carbon dioxide (CO <sub>2</sub> )	○	○	○	○	○	○
Methane (CH <sub>4</sub> )	—	○	—	—	—	—